

**Assembly, Care and
Usage Instructions**



STOP!

If you have a problem with this product, **DON'T RETURN IT TO THE STORE WHERE YOU PURCHASED IT.** Contact customer service at...

Battenfeld[™]
Technologies, Inc.

5885 West Van Horn Tavern Road / Columbia, MO 65203
573-445-9200 / Email: sales@battenfeldtechnologies.com
Or visit our website @ www.battenfeldtechnologies.com

NOT WARRANTIED AGAINST MISUSE, ABUSE, OR COMMERCIAL USE.

Limited Warranty

Every Tipton product is warrantied to be free of defects in materials and workmanship for a period of one (1) year from the date of original purchase. Tipton will, at its option, repair or replace without charge, except for transportation costs, parts that fail under normal use and service when operated and maintained in accordance with our Instructions. This warranty does not apply to normal wear or to items whose life is dependent upon their use and care. This warranty is in lieu of all other warranties, expressed or implied and releases Tipton, its affiliates, and its vendors from all other obligations and liabilities.



WARNING: IMPORTANT SAFETY INFORMATION!

- To avoid serious injury or death, follow this safety information.
- Always practice safe firearm handling.
- Make sure firearm is unloaded before using this product.
- This product contains lead, a chemical known to the state of California to cause cancer, birth defects and other reproductive harm.
- Keep these instructions for future use.

Thank you for purchasing the TIPTON® Deluxe Bore Guide Kit. Please read the instructions thoroughly before attempting to clean your firearm. Since we are always trying to improve our products, some components may vary slightly in appearance.

The Deluxe Bore Guide Kit includes the following items:

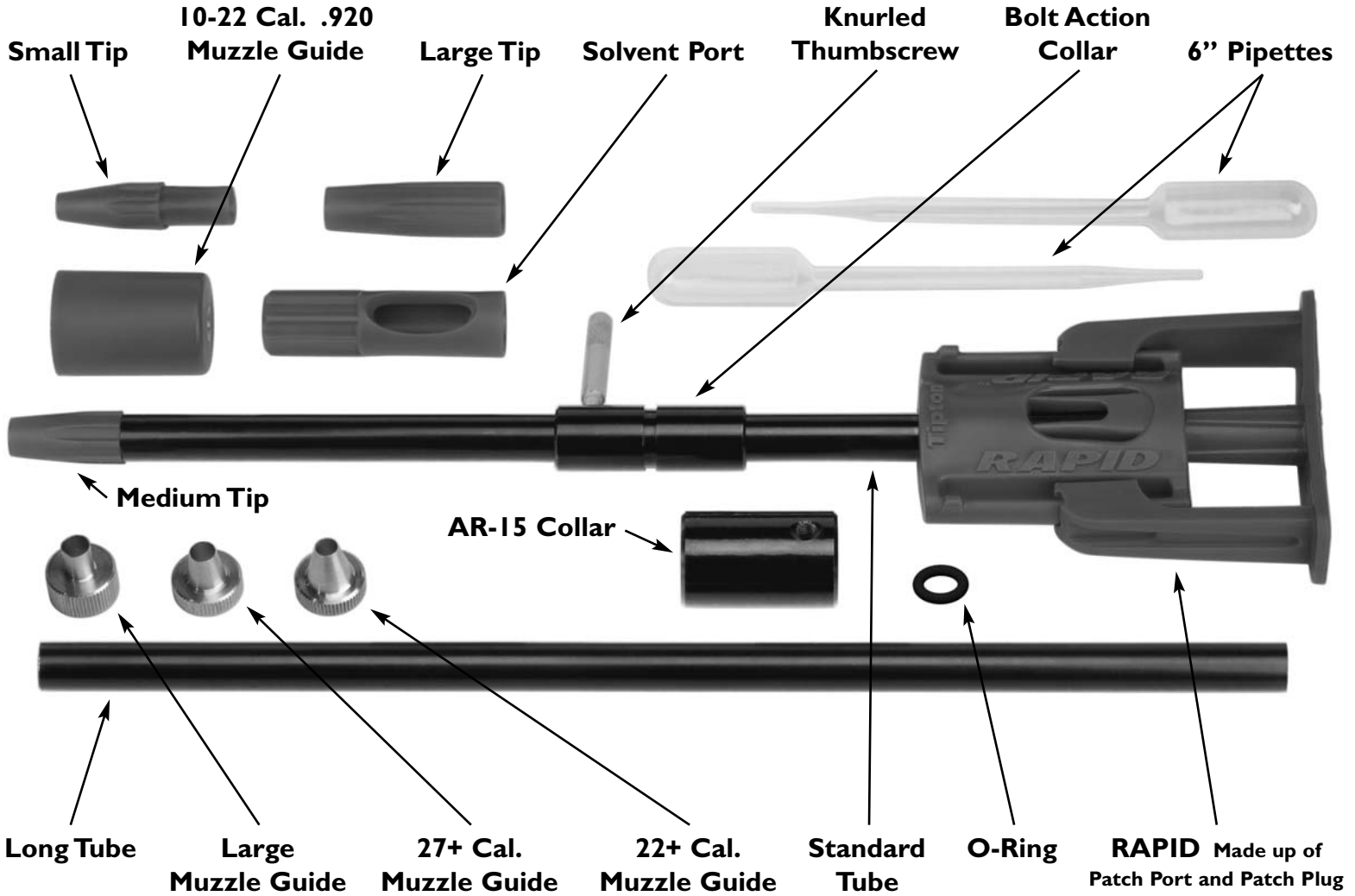

Why use a Bore Guide

The use of a bore guide protects the critical surfaces of the rifle bore. Damage to the chamber can take place when cleaning components such as jags, brushes and the rod come in contact with these precision surfaces. The use of a Bore Guide maintains a central location of these components and controls rod flex while cleaning. A Bore Guide also keeps solvents and oils out of the action.

Why use a Muzzle Guide

Most rifles have machined profile at the end of the barrel called the "crown". This machined feature creates a recess to protect the lands and grooves where they intersect the end of the barrel. The crown is the last surface the base of the bullet makes contact with before leaving the barrel. Imperfections along this intersection will cause irregular barrel pressures to push the bullet off target.

How to use the Basic Bore Guide

The Bore Guide is simple to use.

1. Install the appropriate tip for your rifle
2. Remove bolt and insert guide
3. Adjust sliding collar for snug fit into chamber and tighten thumbscrew and you are ready to clean.

Three interchangeable tips cover most calibers from .17 to .460. Note: The tips insert into the chamber and chamber dimensions do not directly correlate to bore diameter, select the tip that provides the best fit for any given cartridge.

SMALL: most cartridges .17 - .24 (up to 6mm)

MEDIUM: most cartridges .25 - .30 (6.5mm - 7.62mm)

Large: most cartridges over .30 (over 7.62mm)

- Compatible with rods up to .425" in diameter.
- Adjustable position sliding collar for bolt actions works with most centerfire rifles. Fits bolt diameters .695" and larger.
- AR-15 collar fits securely inside receiver of AR-15 style rifles.

How to use a Muzzle Guide

1. Before installing a jag or brush on the cleaning rod, slide the appropriate Muzzle guide over the end of the cleaning rod with knurled surface facing the cleaning rod handle.
2. Install a jag or brush on the cleaning rod
3. Once the jag or brush has been inserted into the barrel, immediately position the Muzzle Guide against the crown of the muzzle
4. Maintain contact between the Muzzle Guide and barrel during the entire cleaning process for maximum protection

How to configure the RAPID

The Patch Plug (1004361), must be configured for either 17-30 or 30-50 CAL patch sizes.

1. Remove the Patch Plug (1004361) by using a light pulling motion until the components are fully separated. Apply equal force to both rails of the RAPID. **(See Photo 1 and 2)**
2. Choose the correct patch range as indicated on the push bar, 17-30 or 30-50 and align your selection to the same side as the solvent port. This step is necessary due to different built-in stops for the two patch ranges.
3. Align both rails and apply equal force to reassemble.



How to use the RAPID

1. Fully open the RAPID and insert a patch between the Patch Plug and the Patch Port. It is important that the patch be centered in front of the Patch Plug cone. **(See Photo 3)**
2. Simultaneously release the patch to maintain a central location while closing the RAPID. **(See Photo 4)**
3. Apply solvent or oil through the hole in the top using a Pipette to wet the patch. **(See Photo 5)**
4. The RAPID will hold the patch until it has been pierced by the jag, continue to push the rod until the RAPID releases the patch. **(See Photo 6)**

